

Slide Station in Stainless Steel

75

90

110

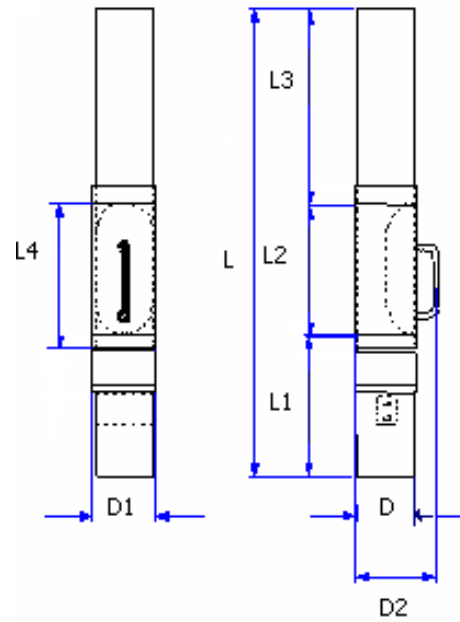
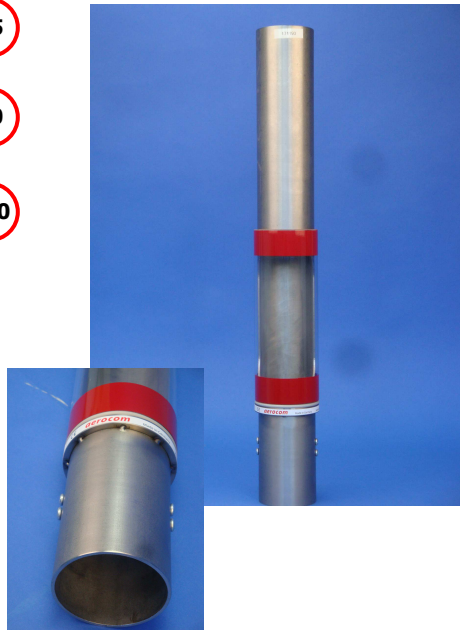

OD	Article no.	D	D1	D2	L	L1	L2	L3	Carrier length
75	171 193	80	90	125	650	145	185	320	235mm
75	171 194	80	90	125	820	245	283	292	325mm
90	171 164	89	100	134	820	245	270	305	305mm
110	171 165	108	120	153	1050	235	320	495	350mm

Use:

As initial- or end station. Tube approaching from top.

Dispatch:

Open slide sleeve and insert the carrier into the send-opening. By pressing a button it will be transported to its destination.

Receive:

An arriving carrier remains in the station and can be removed by opening the slide sleeve.

Easy of Use/Quality/ Technique:

- Stainless Steel tube, wall thickness 2mm
- Transparent slide sleeve for the control of an arriving carrier
- Separate send-button with operation indication
- Tube connection always to above
- An external bypass generates a soft arrival of the carrier
- The arriving carrier operates a tube switch, which is disconnecting the system

aerocom

Aerocom GmbH & Co
 Adam-Riese-Str. 16
 73529 Schwaebisch Gmuend
 Germany

Phone +49.71 71.10 45 0
 Fax +49.71 71.10 45.2 99
 info@aerocom.de
 www.aerocom.de